

STORMWATER TIE BLOCKAGES AND DAMAGE REIMBURSEMENTS

WHEN OCCURRING WITHIN ACT GOVERNMENT INFRASTRUCTURE

On Site Process Checklist (Refer Section 3):

Process Step	Description	Complete/Incomplete	Policy Reference
Step 1	Property inspected by plumber/drainer and ACT Government land identified	<input type="checkbox"/> Yes <input type="checkbox"/> No <input type="checkbox"/> NA	Section 3 and 5
Step 2	Roads ACT contacted and site meeting arranged	<input type="checkbox"/> Yes <input type="checkbox"/> No <input type="checkbox"/> NA	Section 3 and 5
Step 3	Pro Forma Completed during inspection and given to Roads ACT rep.	<input type="checkbox"/> Yes <input type="checkbox"/> No <input type="checkbox"/> NA	Section 3 and 5
Step 4	Stormwater tie exposed at property boundary and Roads ACT representative has inspected blockage/damage prior to backfill	<input type="checkbox"/> Yes <input type="checkbox"/> No <input type="checkbox"/> NA	Section 3 and 5
Step 5	Plumber/drainer has undertaken repair works in accordance with this policy and relevant standards	<input type="checkbox"/> Yes <input type="checkbox"/> No <input type="checkbox"/> NA	Section 3 and 5
Step 6	Reimbursement Pro Forma lodged with Roads ACT in accordance with Policy Process	<input type="checkbox"/> Yes <input type="checkbox"/> No <input type="checkbox"/> NA	Sections 6, 7 and 8

Version 5 – July 2018

Contents

1	Policy Objective.....	2
2	Introduction	2
3	Recommended Process	2
4	Accessibility Disclaimer	4
5	Resolving Stormwater Tie Blockages in the ACT	5
6	Eligibility for reimbursement	6
7	Standard Reimbursement Amounts.....	6
8	How to Apply For a Reimbursement.....	7
9	Technical Information	8
10	Diagrams	9
11	Access Canberra Process Map	12
12	Reimbursement Pro Forma.....	13

Document Status

Created by:	Jared Falkenhagen	Jared Falkenhagen	Jared Falkenhagen	Nicholas Kerr	Nicholas Kerr
Reviewed by:	Michael Hill	Michael Hill	Michael Hill	Michael Hill	Michael Hill
Approved by:	Tony Gill	Tony Gill	Tony Gill	Ken Marshall	Ken Marshall
Version:	1	2	3	4	5
Status:	Draft	Draft	Final	Final	Final
Date Approved:	August 2015	November 2015	January 2016	July 2017	July 2018

1 Policy Objective

- 1.1 The following document outlines a fair process to resolve stormwater tie blockages and damage occurring within ACT government infrastructure; in particular reimbursement of private contractors involved in the works. The result is a reasonable price for the works completed by a private contractor, having ensured a satisfactory and safe outcome was achieved.

2 Introduction

- 2.1 A stormwater tie can be described as the connection of the public stormwater services to individual properties. The stormwater tie can be connected via a pipe to a stormwater main, or to the kerb of a street. In either case, the property boundary creates the distinction between the property on private land, and the property of the ACT Government. This involves a connection point; and can include an access “riser” that can be used as an inspection point and as an access point for cleaning services. The riser is located at the boundary between private and public land. The stormwater drainage services within private land are the sole responsibility of the lease holder. Any blockages or damage within private land is the obligation of the lease holder to clear or repair. All stormwater drainage services outside of the private land boundary is the responsibility of the ACT government to maintain.
- 2.2 A blockage is determined as an obstruction which significantly impedes stormwater flow causing significant back water.
- 2.3 The ACT Government does not automatically accept responsibility for damage or blockages until the circumstances have been thoroughly investigated. Responsibility can often lie solely with the private land lease holder. This includes blockages that occur in public property, but emanate from the private stormwater drainage, i.e. cement washed down into the stormwater network from private stormwater drainage.
- 2.4 The ACT Government reserves the right to amend this document at any time, to retain currency.

3 Recommended Process

- 3.1 When a blockage occurs, the lease holder should call a private plumber/drainer to investigate the issue. Alternatively, the lease holder can contact Access Canberra, on 13 22 81 or www.accesscanberra.act.gov.au, for further information. Refer to the Process Chart in Section 5 - Figure 1 for a visual guide. As an alternative, the online resource Fix My Street <https://www.accesscanberra.act.gov.au/app/forms/fixmystreet/> may be used to lodge a blocked stormwater tie with Access Canberra.
- 3.2 The plumber/drainer clears from the top end of the private lease drainage and proceeds to go downstream until the blockage is cleared, or a major obstruction or blockage is encountered on ACT Government land.

3.3 The plumber/drainage should contact Access Canberra if it is established that:

- (a) The blockage is in the public stormwater main, or;
- (b) The blockage is within ACT government land.

An inspection must be arranged with a Transport Canberra and City Services (TCCS) representative to investigate the blockage or damage at the tie point, to verify the claim. Disregarding this direction may jeopardise any reimbursement.

- 3.4 Roads ACT will arrange an on-site meeting with the plumber/drainage within 2 business days from receiving the lodged request from Access Canberra.
- 3.5 Having contacted TCCS and a site meeting has been arranged, the plumber/drainage shall expose the tie point at the boundary of private and public land in preparation for the agreed inspection.
- 3.6 Ensuring the excavation meets satisfactory safety requirements at the completion of inspection and TCCS have advised, excavation shall be backfilled. For further information, see Section 9.
- 3.7 At this point, a decision will be made as to whether TCCS will accept responsibility for the works. If responsibility is accepted, the appropriate government contractor will be called by TCCS to complete the works. The private plumber/drainage may be requested by the TCCS representative to install a riser at the tie point on the property boundary, and backfill the excavation, dependent on site specific requirements.
- 3.8 The riser must conform to plumbing standards (AS3500.3 2003), and be of satisfactory quality to warrant reimbursement. See Figure 2 - Riser Installation Diagram A, and Figure 3 - Riser Installation Diagram B, for further specifications of pipe sizes and bend requirements.
- 3.9 In the case of a kerb connection, no excavation is to be undertaken, as kerbside access for pipe clearing is available. Any works deemed unnecessary by the TCCS representative will not be reimbursed.
- 3.10 The private plumber/drainage is to submit the supplied pro forma (See section 12) verifying their segment of the works directly to TCCS for reimbursement consideration, along with all supporting documents as outlined in Section 8. TCCS will not accept pro forma submissions dated in excess of 3 months from works completed.
- 3.11 A breakdown of the reimbursement amounts can be seen in Section 7.
- 3.12 The following points should be noted and understood in relation to the matter of stormwater tie damage or blockages:
 - (a) CCTV camera footage is not acceptable as sufficient evidence of a blockage.
 - (b) An assertion by the plumber/drainage that the length of coiled rods, eel, or CCTV camera inserted into the drain through an access point on the private land of the lease holder

exceeds the distance from the access point to the lease boundary will not be accepted as evidence that the source of the blockage is beyond the lease boundary.

(c) Should the stormwater tie at the property boundary be under a hardstand or be inaccessible for any other reason, an inspection should take place with the TCCS representative prior to any works being conducted.

(d) In the case of an excavation of over 2.5m deep, TCCS should be contacted, via Access Canberra, prior to works starting.

(e) In all other cases no reimbursement will be payable.

3.13 If any additional work is required, the TCCS representative will carry out another inspection. A written agreement by TCCS, regarding work to be undertaken and agreed costs, will be required to claim any further reimbursement.

3.14 Requests for reimbursement will not be considered unless received within 30 days of the event, unless prior agreements are made.

4 Accessibility Disclaimer

4.1 This document contains elements which cannot be made accessible. If you are experiencing difficulty accessing the information in this document, please contact 13 22 81.

5 Resolving Stormwater Tie Blockages in the ACT

5.1 What is a stormwater tie?

A stormwater tie is the connection of the private stormwater drainage system, servicing the private land, to the government owned stormwater infrastructure. This involves a connection point; and can include an access “riser” that can be used as an inspection point as well as an access point for cleaning services. The riser is located at the boundary between private and public land.

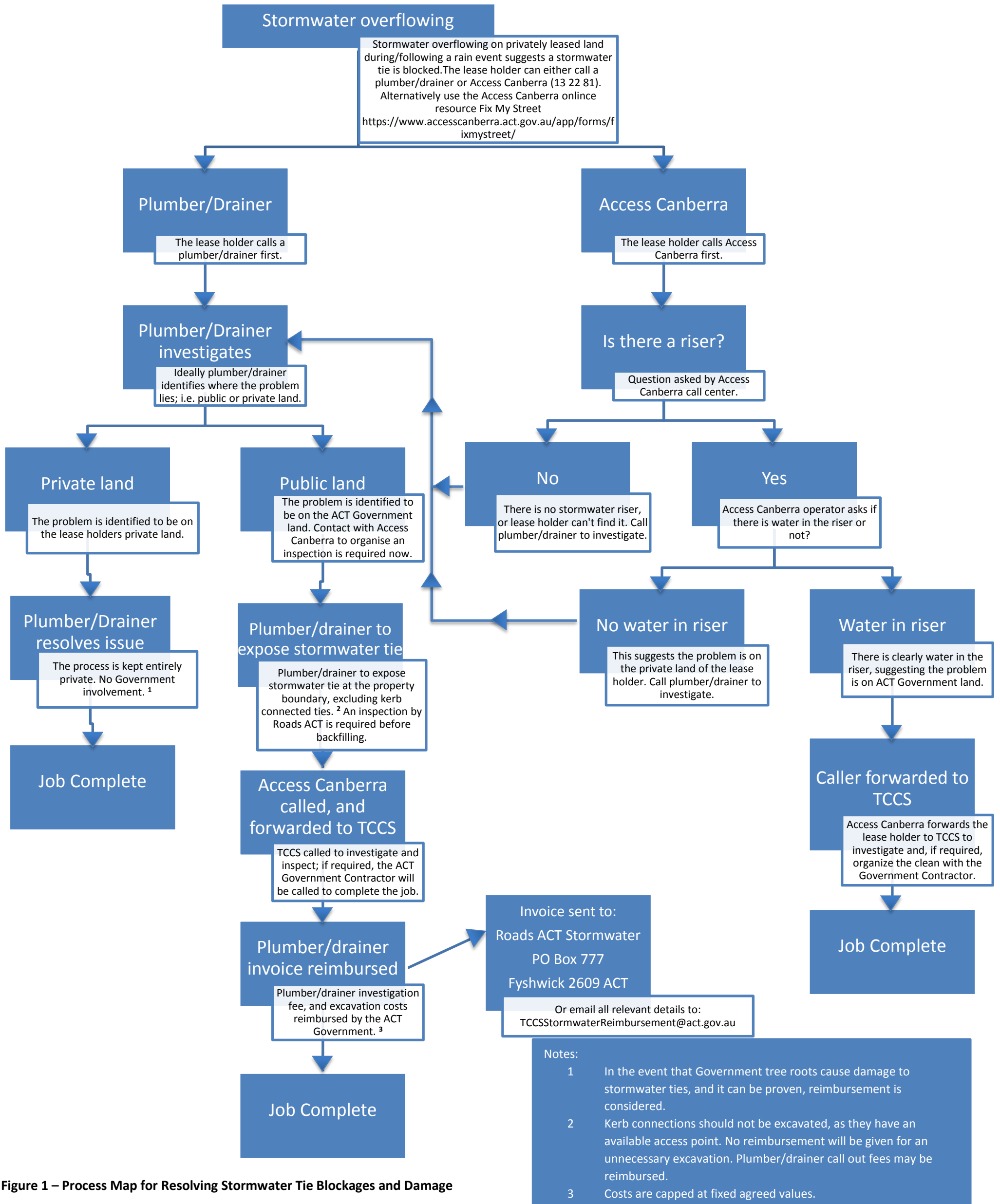

Figure 1 – Process Map for Resolving Stormwater Tie Blockages and Damage

6 Eligibility for reimbursement

- 6.1 The ACT Government is responsible for the stormwater services within ACT Government land. No reimbursements will be given for stormwater blockages occurring on private land, or caused by activities originating from private land.
- 6.2 The works completed by a lease holder or their contractor are to be considered of satisfactory safety and quality standards, having followed this procedure, technical requirements and ACT legislation, to be eligible for the reimbursement.
- 6.3 The works considered eligible for reimbursement can include, but are not limited to:
- (a) Work done in establishing that the blockage was in the stormwater main or tie line on ACT government land, and/or;
 - (b) Excavation to expose the tie point, having established the blockage or damage is outside the private land boundary, and/or;
 - (c) Installation of a stormwater inspection riser, and/or;
 - (d) Backfilling of excavations and surface treatment.

7 Standard Reimbursement Amounts

- 7.1 The following reimbursement amounts can be claimed for maintenance works on stormwater ties, based upon varying excavation depths and work completed (GST exclusive):

Reimbursement Description	Investigation Fees (Business Hours)	Investigation Fees (After Hours)	Excavation and Backfill Cost
Stormwater tie is 0mm to 900mm deep at land boundary	\$157.00	\$418.00	\$2,152.00
Stormwater tie is 900mm to 1500mm deep at land boundary	\$157.00	\$418.00	\$3,008.00
Stormwater tie is 1500mm to 2500mm deep at land boundary	\$157.00	\$418.00	\$3,671.00
>2500mm deep	Case-by-case negotiation (prior to works)		

- 7.2 All fees listed above are irrespective of hours worked and ground conditions, as these costs have been factored into the values. Reimbursement for reinstatement of any unapproved landscaping, beyond regular concrete driveway, laying topsoil and seeding, will not be considered; as the

easement act requires this land be free from obstruction. For exceptional occurrences, a written agreement with a TCCS representative may be considered.

- 7.3 The above fees and costs will be reviewed on an annual basis, based on CPI.
- 7.4 Business Hours are between 7am and 5pm (Business Hours) on any Business Day (Monday to Friday excluding public holidays in the ACT).

8 How to Apply For a Reimbursement

- 8.1 When work is complete, the supplied pro forma (Section 12) should be completed, and the plumbers/drainers invoice, addressed to Roads ACT, should be attached and sent to:

Roads ACT
Stormwater
PO Box 777
Fyshwick ACT 2609

OR

Email: TCCSStormwaterReimbursement@act.gov.au

- 8.2 Claims for works completed are to be submitted by the plumber/drainers on numbered invoices detailing labour, materials, plant and equipment, with a description of the works undertaken. Supporting documentation must be attached to the completed pro forma.
- 8.3 Requests for reimbursement will not be considered unless received within 30 days of the event, unless prior agreements are made.
- 8.4 All receipts/invoices for sub-contractors, plant and equipment must be submitted with the claim.
- 8.5 Private plumber/drainers invoices (with TCCS approval) are to be submitted directly to Roads ACT by the plumber/drainers, and not to the private lease holder.
- 8.6 Plumbers/drainers licensed by a professional authority to work in the ACT must provide their licence number and an expiry date with all claims.
- 8.7 For more information, please call Access Canberra on 13 22 81 or visit www.accesscanberra.act.gov.au.

9 Technical Information

9.1 Excavation and Backfill Specifications

- 9.1.1 All trenches greater than 1.6m deep are to be shored. Shoring may be either timber shoring or moveable metal shield shoring. Where shoring is required, ladders shall be provided. Alternatively, trenches may be benched/stepped to avoid the use of shoring, provided the depth of the deepest trench is not deeper than 1.5m without shoring. Refer to Figure 4 - Benching Diagram.
- 9.1.2 All benches/steps should be wide enough to stabilise the slopes and to prevent material from falling into the working area.
- 9.1.3 Excavation sizes are dependent on depth, however, some standard sizes have been produced;
- (a) Excavation depth of 0mm – 900mm should have a minimum 0.5 metre by 1 metre excavated base to expose the stormwater tie. See Figure 5 – Plan View of Excavation Base Size for 0mm – 900mm.
 - (b) Excavation depth of over 900mm requires at least a 1 metre by 1.5 metre excavated base to expose the stormwater tie; with the length increasing proportionally with depth as required. See Figure 6 – Plan View of Excavation Base Size for >900mm Depth.
- 9.1.4 All work sites are to be left in a safe and secure state.
- 9.1.5 A suitable 1200mm high safety barrier containing the work site is required.
- 9.1.6 Unless otherwise specified do not excavate by machine within one (1) metre of existing services; or within three (3) metres of the dripline of existing ACT Government trees.
- 9.1.7 Backfill of an excavation should be free from stones larger than 100mm, and compacted to the density of the adjacent undisturbed ground. Backfill under a driveway should be subbase material compacted to 90% of modified maximum dry density up to 300mm above the pipe; material lower than 600mm below subgrade level shall be compacted to at least 90% of modified maximum dry density. The top 600mm below road subgrade levels shall be compacted to at least 95 % of the modified maximum dry density.
- 9.1.8 Where relatively short trenches cross existing lawns and when these trenches will be backfilled within two (2) days, turf may be cut out and stacked neatly to one side. Water turf as necessary. On completion of backfilling, replace turf and restore lawn to its original condition. In cases where this is unachievable, topsoil and seed as required
- 9.1.9 For further information on the required standards for backfilling and excavation, please refer to Section 3 – Underground Services of the Standard Specification for Urban Infrastructure Works 3-2 Edition 1, Revision 0, which can be found at <http://www.TCCS.act.gov.au/>; or any subsequent revisions.

10 Diagrams

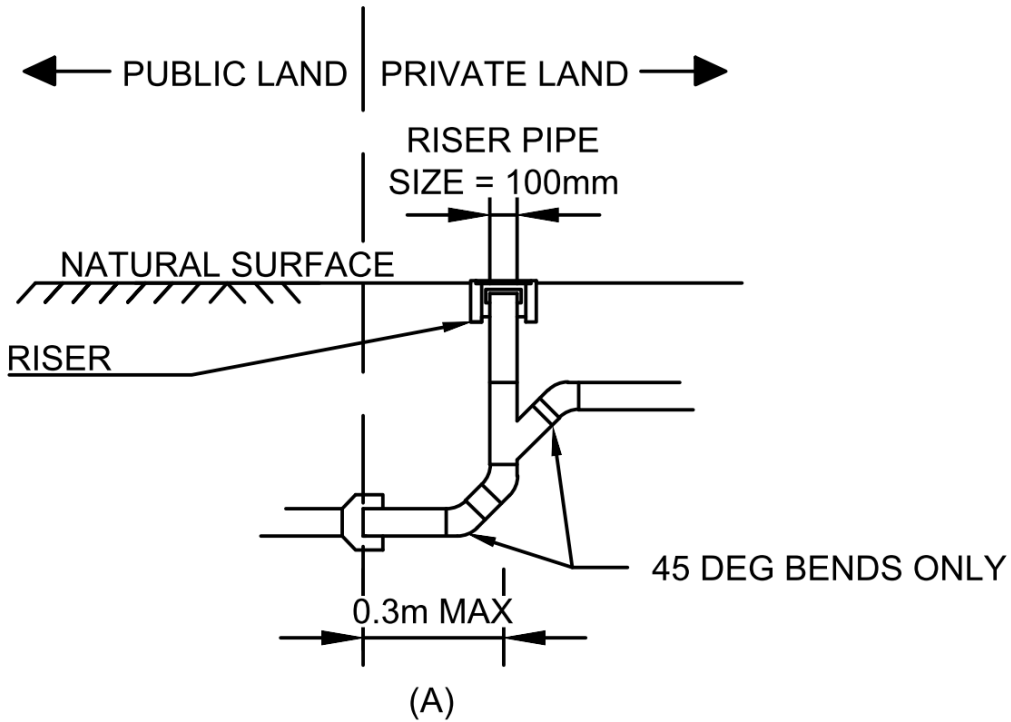

Figure 2 - Riser Installation Diagram A

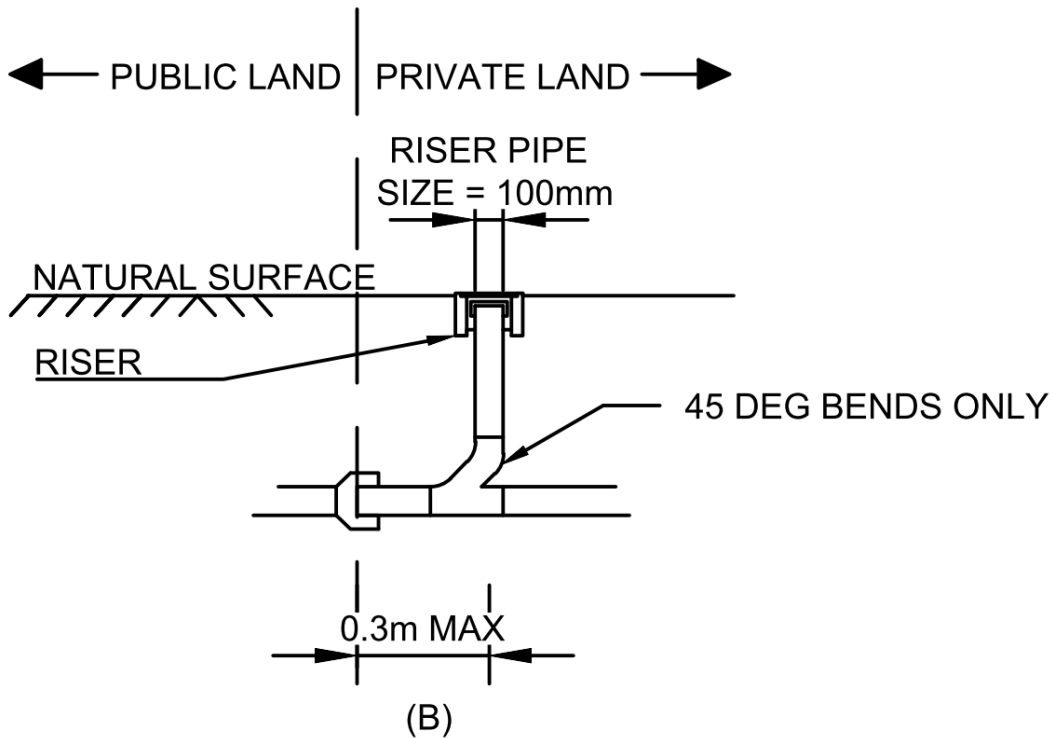

Figure 3 - Riser Installation Diagram B

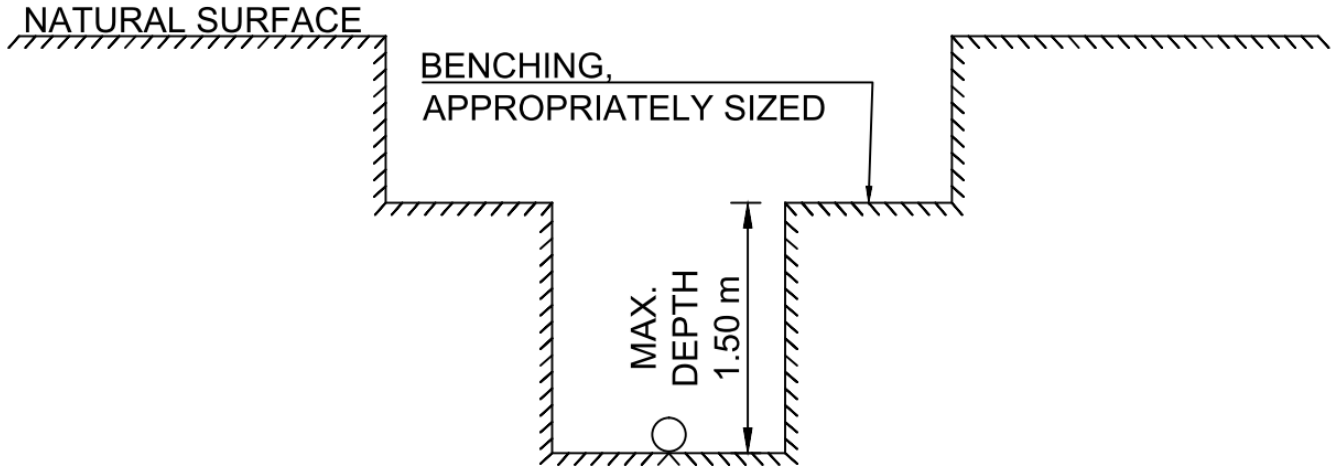

Figure 4 - Benching Diagram

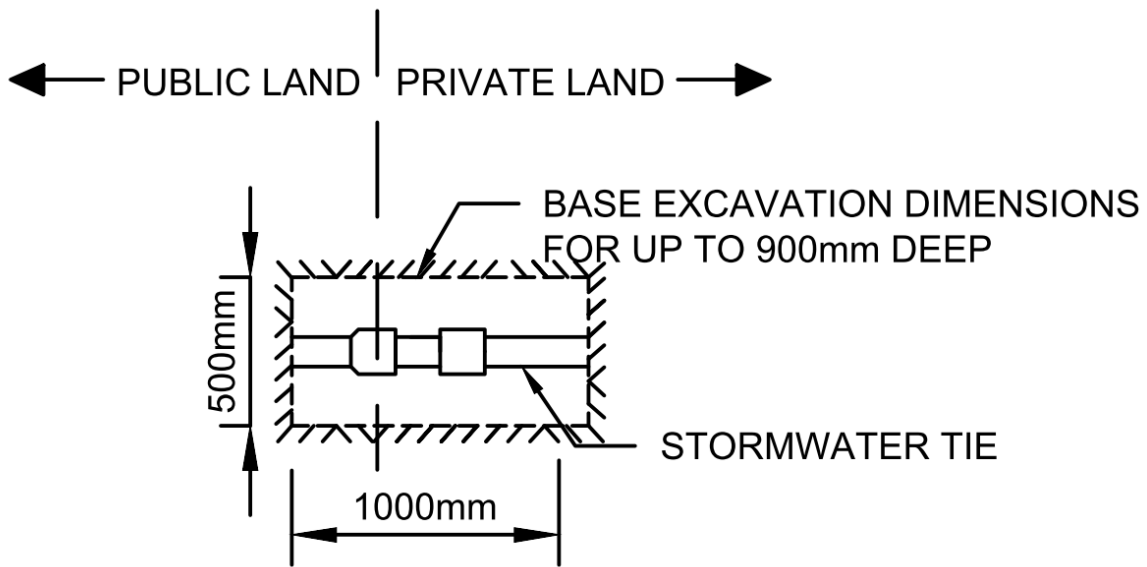

Figure 5 – Plan View of Excavation Base Size for 0mm – 900mm depth

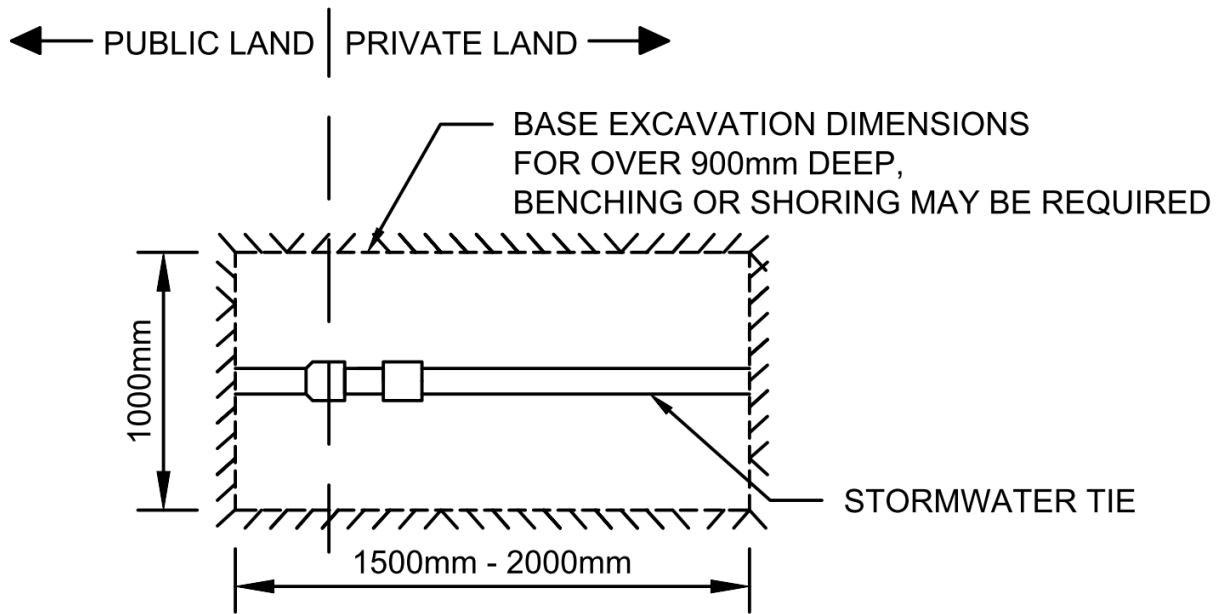

Figure 6 – Plan View of Excavation Base Size for >900mm Depth

11 Access Canberra Process Map

For the use of Access Canberra employees to direct an inquiry from members of the public.



Figure 7 – A round stormwater riser.
Source: <http://www.ri-industries.com.au/wp-content/uploads/2013/03/inspection-flanged-type-1.jpg>

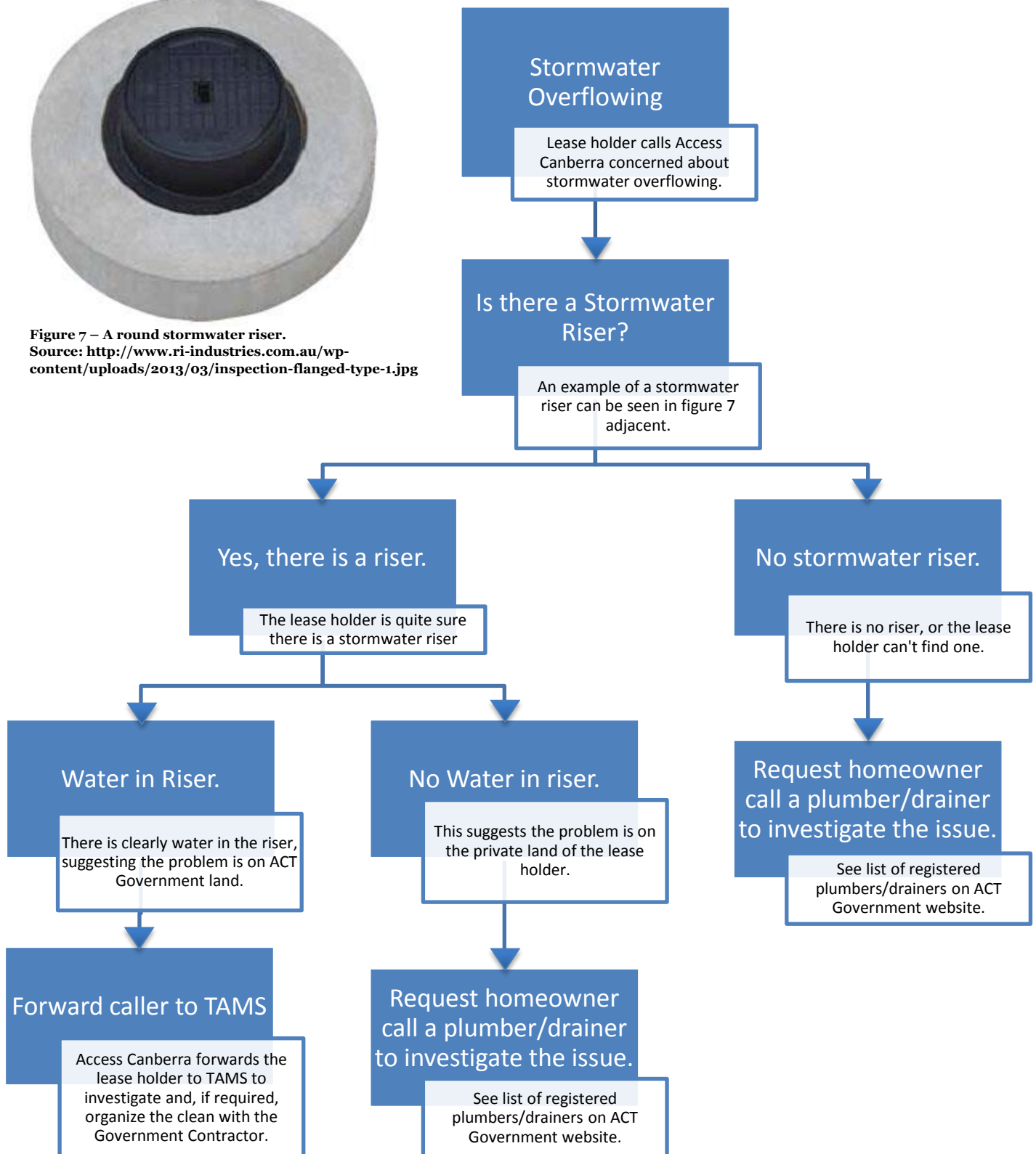



12 Reimbursement Pro Forma

Property Details

Block: _____ Section: _____ Suburb: _____

OR

Address: _____

Contractor Details (if different to lease holder)

Company Name: _____

Contractors Name: _____

Contact Number: _____

Email: _____

Plumber/Drainer License Number _____

Company ABN: _____

Government Representative Details

Representative Name: _____ TCCS Reference Number: _____

Inspection Date: _____ Inspection Time: _____

Declaration

I, _____, guarantee that the works at
(Full Name)

_____ (Address)

have been completed fully and to specified quality. I have informed the lease holder, or a representative of the lease holder, of the reimbursement procedure, and have invoiced Transport Canberra and City Services only.

Contractor Name: _____

Contractor Signature: _____ Date: _____

TCCS Approving Officer: _____

TCCS Approval Signature: _____ Date: _____



Reimbursement Calculation

Please circle the applicable costs below, ensuring the description of works above correlates with the options you select (GST exclusive). Please note the depth will be verified by a TCCS representative at time of inspection. Calculate your total expected reimbursement, and list below in the field provided.

Excavation Depth	Investigation Fees (Business Hours)	Investigation Fees (After Hours)	Excavation and Backfill Cost	Total (To be calculated)
0 mm – 900 mm	\$157.00	\$418.00	\$2,152.00	
900 mm – 1500 mm	\$157.00	\$418.00	\$3,008.00	
1500 mm – 2500 mm	\$157.00	\$418.00	\$3,671.00	
>2500 mm	Case-by-case negotiation			

Total expected reimbursement: \$ _____

Description of Agreed Additional Works

Any additional works completed must be agreed to by TCCS prior to any works starting.

Please detail labour, materials, plant and equipment, and extent of any agreed additional works here:
